

LOGILASE FI

# LOGILASE LASERS

## LOGILASE GALVO FS

### PORTABLE FIBER LASER GALVO HEAD METAL MARKING MACHINE

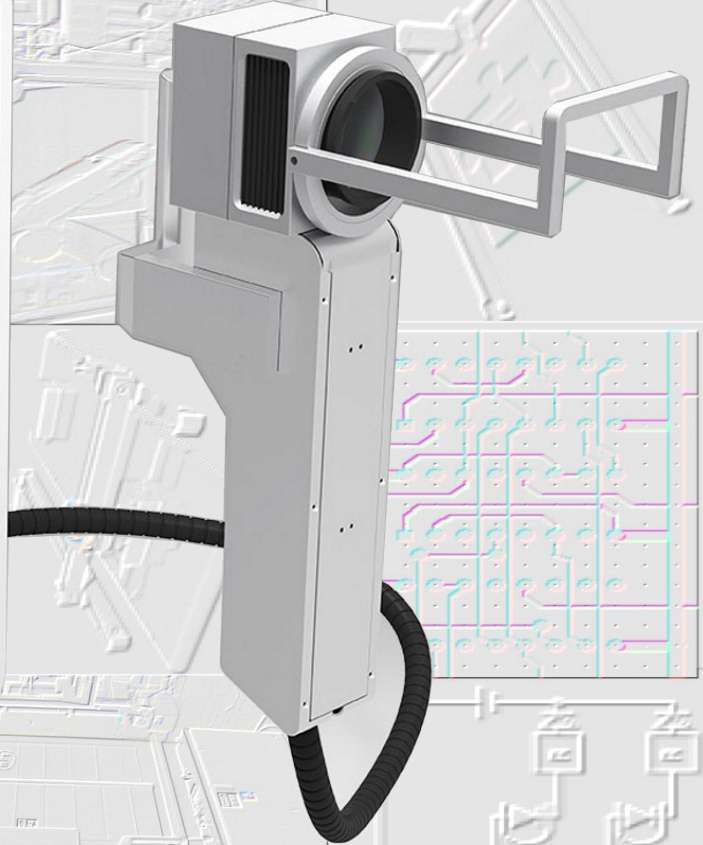

**LOGI MAT ION**  
TECHNOLOGIES, INC.



# LOGILASE GALVO FS

Portable Galvo Head Fiber Laser Metal Marking Machine



## SPECIFICATION

Model	GALVO FS20	GALVO FS30	GALVO FS50
Laser Power	20 W	30 W	50 W
Marking Area	100mm x 100mm OR 200mm x 200mm		
Laser Type	100,000 Hours Life span Air cooled Fiber Laser, 1064 nm, Q: 20-80 KHz		
Laser Head	SCANLAB German Galvanometer with Field lens, Removable		
Divergence	0.3 mrad		
Beam Quality	M2: 1.2~1.8		
Processing Speed	0-7000 mm/s		
Communication (File Transfer)	USB, Ethernet		
Min. Line Width	0.02 mm		
Min. Character size	0.15 x 0.15 mm		
Repeatability	±0.001 mm Accuracy with Red Dot Positioning System		
Controlling Software	EzCad with Bar Code Generator (Win XP/7/8/10 Compatible)		
Compatible Graphic Format	DXF, PLT, BMP, DWG, AI		
Compatible Software	CORELDRAW, AUTOCAD		
Drive System	High-precision Mini Servo Motor		
Power Supply	110-120 V, 60HZ <500 OR 220-230 V 50 HZ, 500 watt		



## SAMPLES



LOGILASE TECHNOLOGIES, INC.

114 Bowes Road, Unit#11, Concord, ON, L4K 1J8, Tel: 416 804 7870, Toll free/Fax: 1 888 686 7485, email: info@logilase.com

www.logilase.com